

TEKNIX

Instruction manual
60cm Induction
Freestanding Cooker

Model: TKED64INDB

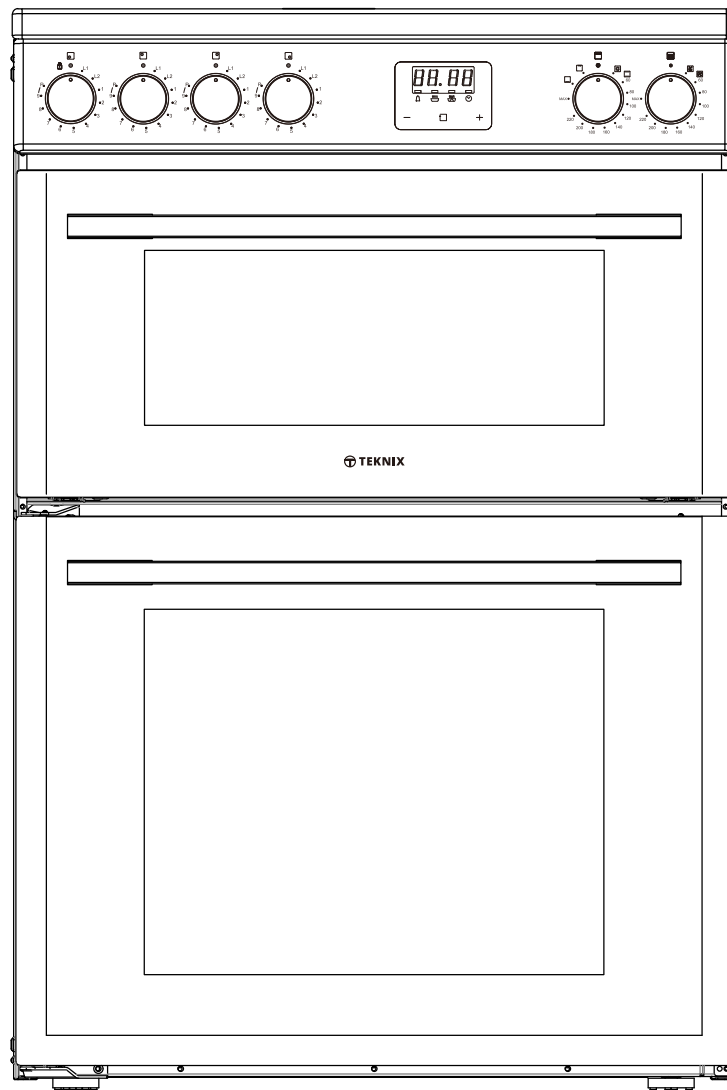

You'll soon be enjoying your new Freestanding Cooker

It all begins here, with your instructions. Don't worry, there's nothing too technical coming up. Just simple, step-by-step guidance to get you up and running quickly. Sound good? Then let's get started.

Contents

Safety information

SAFETY INFORMATION 4

Getting to know your Freestanding Cooker

Overview 8

Accessories 9

Installing your Freestanding Cooker

Installation requirements 10

Electrical connection 12

Using your Freestanding Cooker

Control panel 14

Oven functions 15

General oven and cooking tips 18

Practical Cooking Advice 19

Cooking Tips - Hob 21

Care and maintenance

Cleaning 28

Replacing the oven lamps 29

How to remove the oven doors 29

Technical Data

Technical specification 31

Energy fiche 32

Product support

Troubleshooting 33

Declaration of conformance to product standards 34

Disposal 34

SAFETY INFORMATION

IMPORTANT

Please read these instructions fully before installing or operating.

INSTALLATION WARNINGS

IMPORTANT: Prior to Installation ensure that the local supply conditions (electricity voltage and frequency) are compatible with the requirements of your freestanding cooker.

IMPORTANT: Carefully unpack and examine the appliance for any damage. If you think there is a defect, do not use the appliance and contact your appliance retailer. Packaging materials should be collected together and disposed of immediately as they maybe harmful to children.

IMPORTANT: Keep the electrical cable (not supplied) of your freestanding cooker away from the hot areas of your appliance, do not let the cable touch the appliance. Keep the cable away from sharp edges and heated surfaces.

IMPORTANT: Ensure that the electric supply cable is not trapped or damaged during installation.

IMPORTANT: In the event that the cable connecting your freestanding cooker becomes damaged, it must be replaced by a suitably qualified person. This cable must not be replaced by an unauthorised person.

IMPORTANT: Protect your freestanding cooker against atmospheric effects. Do not expose your cooker to effects such as sun, rain, snow etc.

IMPORTANT: The materials surrounding the appliance (cabinets) must be able to withstand a minimum temperature of 100°C.

IMPORTANT: When using your oven for the first time your cooker may give off an smoke or an unusual odour from the heating elements and insulation materials. To eliminate this odour run the oven at 250 degrees for 40-60 minutes with the oven empty.

WARNING: Before obtaining access to terminals, all supply circuits must be disconnected.

IMPORTANT: Make sure the oven control knobs are all in the off position when not in use.

IMPORTANT: If you do not intend to use your built in oven for a long period of time then turn off the electric supply to the oven.

DURING USAGE

IMPORTANT: This appliance can be used by children aged from 8 years and above and persons with reduced physical, sensory or mental capabilities or lack of

SAFETY INFORMATION

experience and knowledge if they have been given supervision or instruction concerning use of the appliance in a safe way and understand the hazards involved. Children shall not play with the appliance. Cleaning and user maintenance shall not be made by children without supervision.

WARNING: The appliance and its accessible parts become hot during use. Care should be taken to avoid touching heating elements.

WARNING: NEVER try to extinguish a cooking fire with water. Instead switch off the appliance and cover flame e.g with a lid or a fire blanket.

CAUTION: Do not allow children in the kitchen when cooking or after, as the parts may still be hot. Many parts of the cooker will become hot and present a considerable hazard to children.

CAUTION: When the cooker is hot never touch the oven glass by hand or with tools.

CAUTION: Before starting to use your appliance, ensure curtains, paper or flammable items are kept away from your appliance. Do not keep flammable materials inside of or around your cooker.

CAUTION: Take care when closing the oven door that there is nothing obstructing it from closing as this may break the glass door.

IMPORTANT: When using the grill the oven door must be kept closed.

IMPORTANT: When the door of the oven is open, do not hang or lean anything on it. You may unbalance your appliance or damage the door or door hinges.

IMPORTANT: Do not hang towels, dishcloths or clothes from the built-in oven or its handles.

GENERAL SAFETY WARNINGS

IMPORTANT: This appliance has been designed for non-professional, domestic use only. Do not use this oven for commercial use or any other application e.g room heating.

WARNING: Danger of fire: do not store flammable items on or near the cooking surfaces or inside the oven.

IMPORTANT: Do not try to lift or move this appliance by pulling on the door handle.

WARNING: Ensure that the appliance is switched off before replacing the lamp to avoid the possibility of electric shock.

IMPORTANT: Your appliance is produced in accordance with all applicable local and international standards and regulations.

IMPORTANT: Maintenance and repair work must only be performed by authorised service technicians. Installation and repair work that is carried out by unauthorised technicians is dangerous and could invalidate your guarantee.

SAFETY INFORMATION

GENERAL SAFETY WARNINGS

IMPORTANT: Always turn the appliance off before operations such as cleaning or maintenance. You can do this by switching the freestanding cooker off using the cooker isolation switch.

IMPORTANT: Do not remove the control knobs to clean the control panel.

WARNING: Do not use harsh abrasive cleaners or sharp metal scrapers to clean the oven door glass since they can scratch the surface, which may result in shattering of the glass.

WARNING: Metallic objects such as knives, forks, spoons and lids should not be placed on the hob surface since they can get hot.

WARNING: If the surface is cracked, switch off the appliance to avoid the possibility of electric shock.

CAUTION: The cooking process has to be supervised. A short term cooking process has to be supervised continuously.

WARNING: Unattended cooking on a hob with fat or oil can be dangerous and may result in a fire.

TO MAINTAIN THE EFFICIENCY AND SAFETY OF YOUR APPLIANCE, WE RECOMMEND YOU ALWAYS USE OUR AUTHORISED SERVICE AGENTS AND ORIGINAL SPARE PARTS.

FOR ASSISTANCE CALL PRODUCT SUPPORT 01759 487823.

Getting to know your Freestanding Cooker

Ready? Let's begin...

Please read these instructions carefully. They contain important information which will help you get the best from your freestanding cooker and ensure safe and correct installation and operation.

If you require any further assistance, our technical experts are happy to help. For full details, refer to the product support section at the end of these instructions.

Getting to know your Freestanding Cooker

Overview

Overview

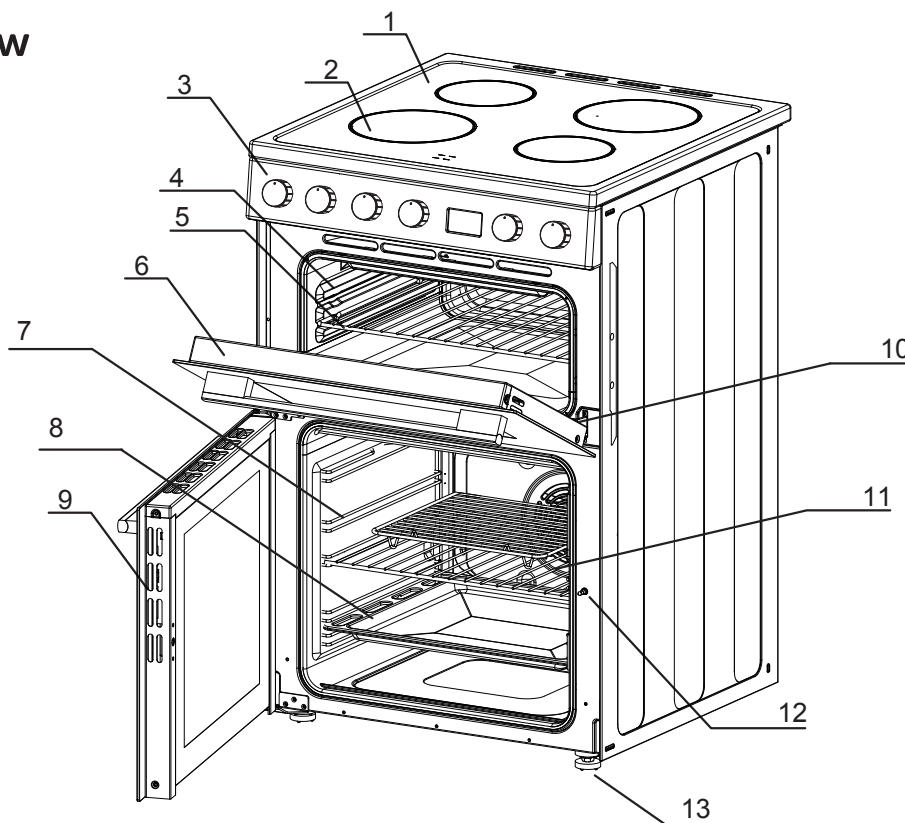

1. Hob
2. Cooking zone
3. Control Panel
4. Shelf positions
5. Wire Shelf
6. Oven Door
7. Shelf positions
8. Baking tray
9. Oven Door
10. Hinge
11. Wire Shelf
12. Door lock
13. Anti slip feet

Getting to know your Freestanding Cooker

Accessories

1.

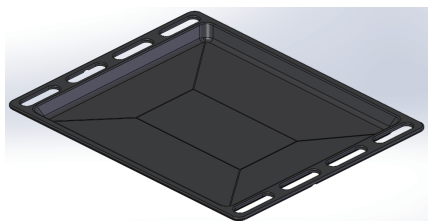

Baking tray x 1

2.

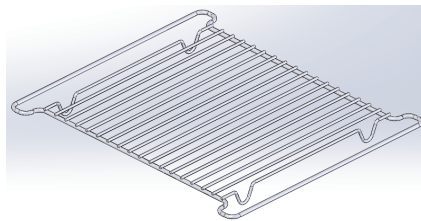

Grill insert x 1

3.

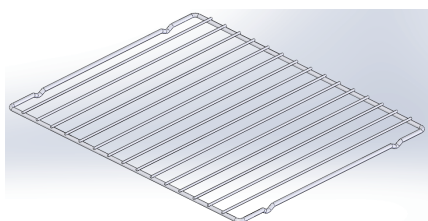

Chrome shelves x 2

Installing your Freestanding Cooker

Installation requirements

THIS COOKER MUST BE INSTALLED BY A QUALIFIED INSTALLER IN ACCORDANCE WITH LOCAL REGULATIONS.

 **IMPORTANT:** CONTACT AN AUTHORISED SERVICE AGENT FOR INSTALLATION OF YOUR FREESTANDING COOKER!

Positioning

1. Make sure that there are no combustible or flammable materials, such as curtains, in the vicinity of the installation.
2. Furniture and cabinets surrounding the cooker must be of material resistant to temperatures greater than 100°C.
3. Surrounding furniture, cabinets and extractor fans should be positioned in accordance with the diagram shown in the figure 1.

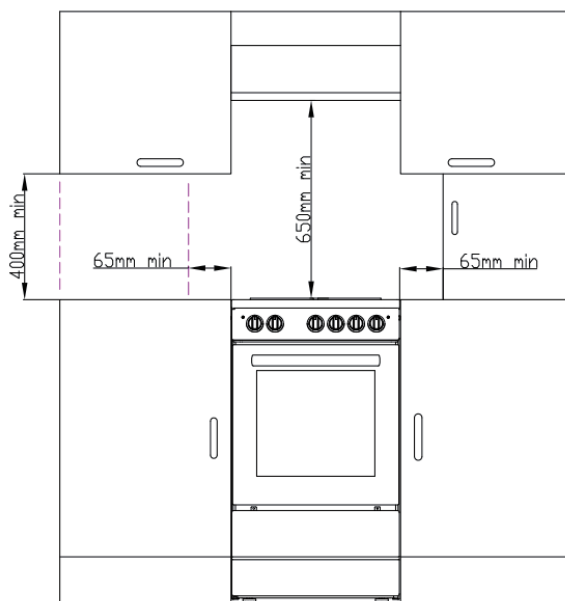

Figure 1

4. There must be at least 2cm of free space between the back wall and the rear of the appliance to allow for ventilation and air circulation.
5. If fitted, the extractor fan must be at least 65cm above the hotplates. If no fan is fitted the minimum distance between the hotplates and any cabinet or other structure must be 75cm.

First Use

IMPORTANT: When using your oven for the first time your cooker may give off smoke or an unusual odour from the heating elements and insulation materials. This is normal for new cookers. To eliminate this odour run the oven at 250 degrees for 40-60 mins with the oven empty.

Installing your Freestanding Cooker

Unpacking

Carefully unpack and examine the appliance for any damage. If you think there is a defect, do not use the appliance and contact Product Support on 01759 487823.

Levelling feet

The height and level of the appliance can be adjusted by rotating the feet located underneath the appliance at each corner. Rotate the feet to decrease or increase the height.

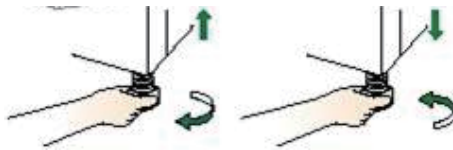

Safety chain

The appliance must be secured against the possibility of tipping forward by using the supplied safety chains attached to the rear of your oven. Fasten the stability hook provided by inserting a wall plug into the kitchen wall and then connect the safety chain to the hook via the locking mechanism.

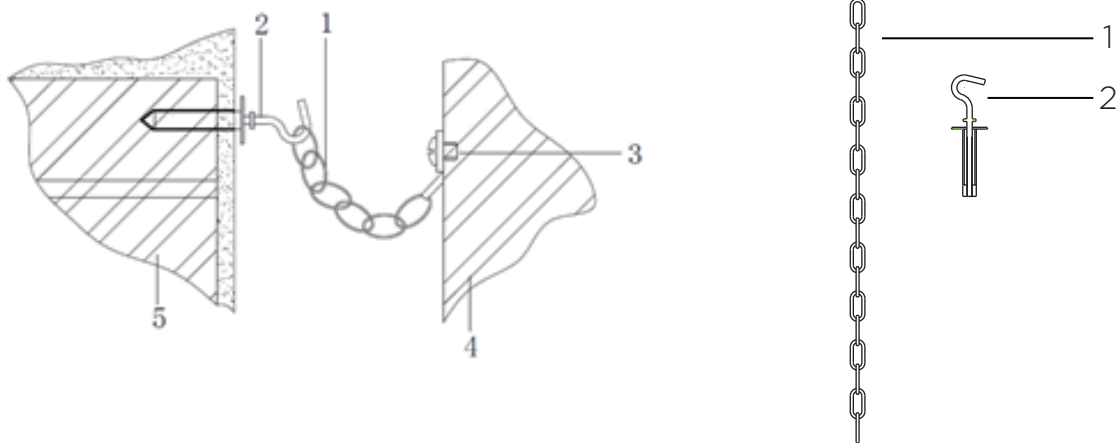

1. Safety chain (supplied and mounted to oven)
2. Stability hook
3. Chain attachment for the rear of the cooker
4. Rear of the cooker
5. Kitchen wall

Installing your Freestanding Cooker

Fitting a Power Supply Cable

⚠ WARNING: Installation MUST ONLY be carried out by a qualified approved installer, ie. an Electrician.

Connecting appropriate power supply 'terminal board/ connector block':

👤 REFER to TECHNICAL table at the rear of this manual for correct rating for your corresponding model purchased.

1. Using a screwdriver, prize open tabs of the Terminal board cover.
2. Remove the wire clamp screw.
3. Fasten the wires beneath the corresponding screw heads, using brass 'bridge' for single phase supply.
4. Fasten cable clamp and close the cover of the terminal board.
5. The AC power supply should be 220-240V or 380-415V, 50-60Hz.

⚠ WARNING: Connect the power cord must be in accordance with the instructions listed in the table below:

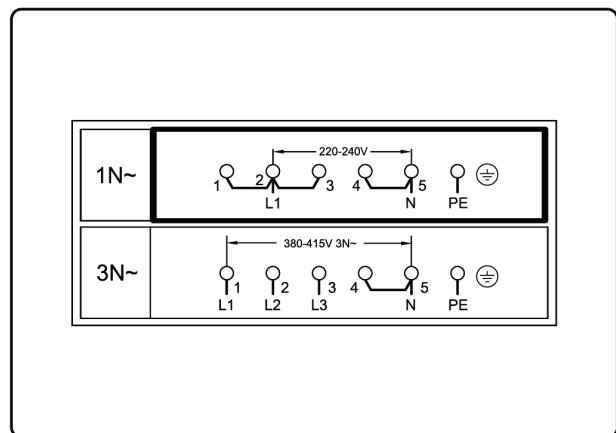
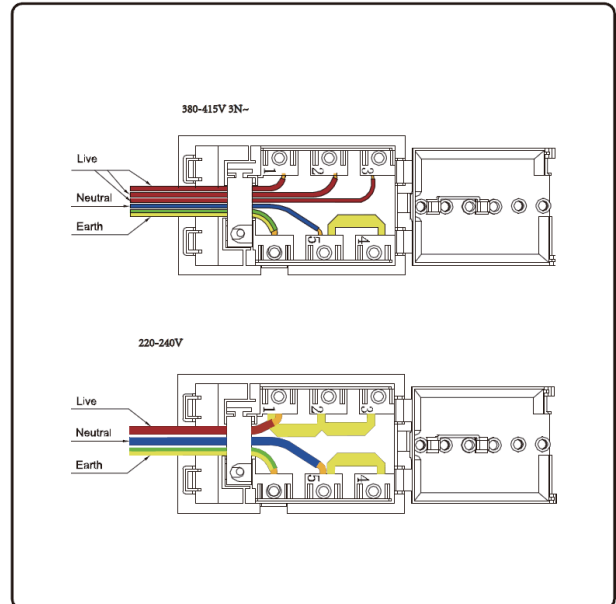

Wire cross-sectional area (mm ²) connection mode	L1	L2	L3	N	E
220-240V 1N~	4 mm ²	-	-	4 mm ²	4 mm ²
380-415V 3N~	Min 2.5	Min 2.5	Min 2.5	Min 2.5	Min 2.5

Installing your Freestanding Cooker

The supply cable should be positioned so that it does not reach a temperature of more than 50°C with respect to the room temperature, anywhere along its length. Before switching fuse ON in meter-box check:

- Earth continuity. The electrical safety of this appliance can only be guaranteed if the cooker is correctly installed and earthed, in compliance with regulations on electrical installations.
- The electrical capacity of the system and sockets will support the maximum power of the appliance, as indicated on the data plate.

Installing your Freestanding Cooker

Control panel

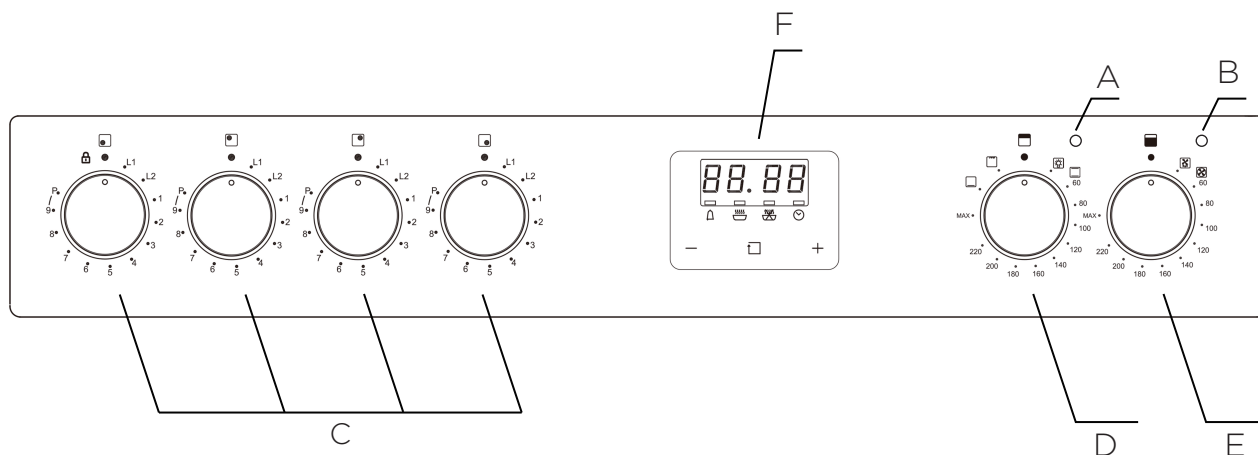

A Indicator lamp for top oven

- The indicator lamp will illuminate when oven is heating up until it reaches the selected temperature.

B Indicator lamp for lower oven

- The indicator lamp will illuminate when oven is heating up until it reaches the selected temperature.

C Induction Hob Control Knob - can be rotated in either direction

- Adjusts temperature of hob.

D Top Oven Temperature/Function Control Knob

- Sets temperature/mode for oven.

E Lower Oven Temperature/Function Control Knob

- Sets temperature/mode for oven.

F Programmable Timer

- Sets cooking duration .

Using your Freestanding Cooker

Oven functions

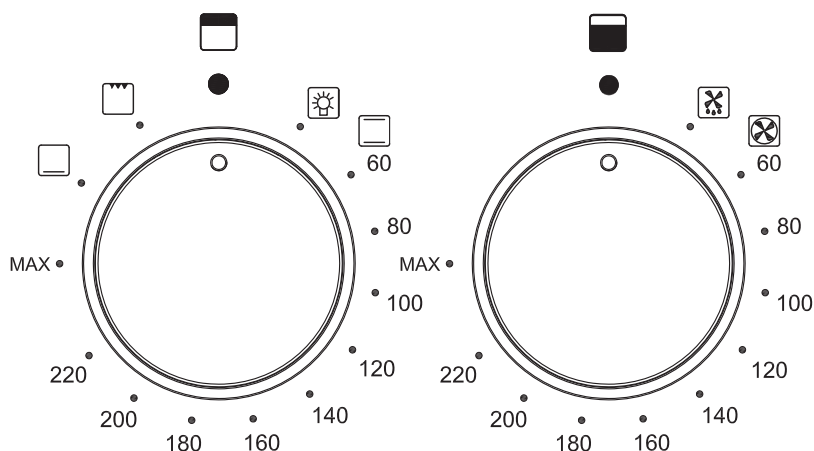

Grill

The top central heating elements comes on. The extremely high and direct temperature of the grill makes it possible to brown the surface of meats and roasts while locking the juices in to keep them tender. The grill is also highly recommended for dishes that require a high temperature on the surface: beef steaks, veal, rib steak, fillets, hamburgers etc.



Conventional

Hot air comes from the upper and lower element in the oven. This is called Conventional cooking and is ideal for joints of meat.



Bottom Element

Bottom element cooking is used for foods that typically need cooking with heat from underneath - Cakes and Bread are examples of where this function would be useful.



Defrost

When set to 'Defrost' mode, the fan located at the back of the oven circulates room temperature air around the food. This is recommended for the defrosting of all types of food, but in particular for delicate types of food which do not require heat, for example: ice cream cakes, cream or custard desserts, fruit cakes, etc. By using 'Defrost' mode, the defrosting time is approximately halved.

Using your Freestanding Cooker



Fan Oven

When set to Baking mode, the fan element and the fan operate providing a delicate heat distributed uniformly throughout the oven. This mode is ideal for baking and cooking delicate foods on multiple shelves, especially cakes that need to rise such as cream puffs and for certain tartlets, sweet or savory biscuits, savory puffs, swiss rolls and small portions of vegetables, etc.



Oven light

The oven light will operate on all oven functions.

Using your appliance for the first time

The first time you use your appliance, we recommend that you set the temperature setting to the highest mark. Set the function switch control knob to a cooking mode and leave the oven on for about 40-60 minutes with nothing in it and the oven door shut. Then, open the oven door and allow the oven to cool. Any odour that may be detected during this initial use is due to the evaporation of substances used to protect the oven during storage.

Using your Freestanding Cooker

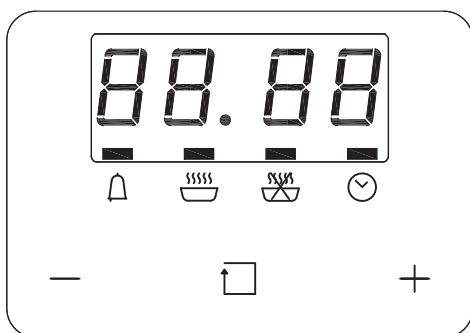

Programmable Timer

Clock setting

Set the time before you start using the oven.

When connecting the appliance to the electrical power supply for the first time or after a mains power failure, the "🕒" symbol will flash.

Press the "+" or "-" button to set the time. After approximately five seconds the indicator light will stop flashing and the display will show the set time.

To change the time subsequently, press the function selection button "⏮" until the "🕒" symbol starts flashing, then press the "+" or "-" button to set the correct time.

Manual cooking procedure (without using the cooking programmer)

To switch on and use the oven in manual mode (disabling the cooking programmer), simply set the cooking mode selection knob to the required position and then set the temperature on the thermostat knob.

To switch off the oven set both the knobs to the top position "0".

Timer cooking procedure

-Cooking time setting

1A - Set the cooking duration (max 10 hours). Press the function selection button "⏮" repeatedly until the "🍲" symbol starts flashing, then press the "+" or "-" button to set the cooking duration;

2A - Having no further settings in a few seconds, the "🍲" symbol will stop flashing and turn always lighted, immediately cooking is started. When cooking is ended the oven will automatically switch off, the "🍲" symbol will flash and the alarm will sound. To mute the alarm press any key; after one minute the alarm will switch off automatically.

- Cooking end time setting



1B - Set the cooking end time (current clock time + up 10:00 max). Press the function selection button "⏮" repeatedly until the "🕒" symbol starts flashing, then press the "+" or "-" button to set the cooking end time.



2B - Having no further settings in a few seconds, the "🕒" symbol will stop flashing and turn always lighted, immediately cooking is started. When the set time is reached the oven will switch off automatically, the "🕒" symbol will flash and the alarm will sound. To mute the alarm press any key; after one minute the alarm will switch off automatically.

Using your Freestanding Cooker

Timer setting

The longest settable time interval is 23 hours and 59 minutes.

1 - To set the time, press the function selection button "  " repeatedly until the "  " symbol starts flashing, then press the "+" or "-" button to set the required time, which will be shown on the display;

2 - After having set the time (hours, minutes) the "  " symbol will flash and the countdown will start. Once the set time has been reached the "  " symbol will flash and the alarm will sound. To mute the alarm press any key; after one minute the alarm will switch off automatically.

The oven light

Set cooking mode selection knob to  symbol to switch on the oven light/s. The oven light/s stay on when the oven is operating.

Using your Freestanding Cooker

Practical Cooking Advice

The oven offers a wide range of alternatives which allow you to cook any type of food in the best possible way. With time you will learn to make the best use of this versatile cooking appliance and the following directions are only a guideline which may be varied according to your own personal experience.

Preheating

You should always preheat your oven before placing food in it to cook.

Once the food has been placed in the oven, the most appropriate cooking mode can then be selected.

Using the Grill

Use the grill mode , placing the food under the center of the grill (situated on the 3rd or 4th rack from the bottom) due to the central part of the top heating element being active.

Please use the grill pan set provided ensuring that there is no unwanted spillages formed inside your oven. When using this mode, we recommend you set the thermostat to the highest setting. However, this does not mean you cannot use lower temperatures, simply by adjusting the thermostat knob to the desired temperature.

When using this mode, we advise you to set the thermostat to 200°C, as it is the most efficient way to use the grill, which is based on the use of infrared rays.

Baking Cakes

When baking cakes, always place them in a preheated oven. Make sure you wait until the oven has been preheated thoroughly (the pilot lamp will turn off). To prevent cake from dropping/sinking – do not open the oven door during baking.

Pastry is too dry

Increase the temperature by 10°C and reduce the cooking time.

Pastry dropped

Use less liquid or lower the temperature by 10°C.

Pastry is too dark on top

Place it on a lower rack, lower the temperature, and increase the cooking time.

Cooked well on the inside but sticky on the outside

Use less liquid, lower the temperature, and increase the cooking time.

The Pastry sticks to the pan

Grease the pan well and sprinkle it with a dusting of flour or use greaseproof paper.

Using your Freestanding Cooker

Use a lower temperature setting. It is not necessary to remove the food from all the racks at the same time.

Cooking Fish and Meat

When cooking white meat, fowl and fish, use temperature setting from 180°C to 200°C.

For red meat that should be well done on the outside while tender and juicy in the inside, it is a good idea to start with a high temperature setting (200°C-220°C) for a short time, then turn the oven down afterwards.

In general, the larger the roast, the lower the temperature setting. Place the meat on the center of the grid and place the dripping pan beneath it to catch the fat.

Make sure that the grid is inserted so that it is in the center of the oven. If you would like to increase the amount of heat from below, use the low rack heights. For savory roasts (especially duck and wild game), dress the meat with lard or bacon on the top.

Using your Freestanding Cooker

COOKING TIPS - HOB

Take care when frying as oil and fat heat up very quickly, particularly if you're using the boost setting. At extreme high temperatures oil and fat may ignite spontaneously which could present a serious fire risk.

When food comes to the boil, reduce the power setting.

Using a lid will reduce cooking times and save energy by retaining heat.

Minimise the amount of liquid or fat to reduce cooking times.

Start cooking on a high setting and reduce the setting when the food has heated through.

Simmering, cooking rice

Simmering occurs below boiling point, at around 85°C, when bubbles are rising occasionally to the surface of the water or sauce. It is the key to delicious soups and tender stews because the flavours develop without overcooking the food. You should also cook egg-based and flour thickened sauces below boiling point.

Some tasks, including cooking rice by the absorption method, may require a setting higher than the lowest setting to ensure the food is cooked properly in the time recommended.

Searing Steak

To cook juicy flavoursome steaks:

1. Stand the meat at room temperature for about 20 minutes before cooking.
2. Heat up a heavy-based frying pan.
3. Brush both sides of the steak with oil. Drizzle a small amount of oil into the hot pan and then lower the meat onto the hot pan.
4. Turn the steak only once during cooking. The exact cooking time will depend on the thickness of the steak and how "well done" you want it. Times may vary from about 2-8 minutes per side. Press the steak to gauge how cooked it is - the firmer it feels the more 'well done' it will be.
5. Leave the steak to rest on a warm plate for a few minutes to allow it to relax and become tender before serving.

Using your Freestanding Cooker

For stir-frying

1. Choose an induction compatible flat-based wok or a large frying pan.
2. Have all the ingredients and equipment ready. Stir-frying should be quick. If cooking large quantities, cook the food in several smaller batches.
3. Preheat the pan briefly and add two tablespoons of oil.
4. Cook any meat first, and then put it aside and keep warm.
5. Stir-fry the vegetables. When they are hot but still crisp, turn the cooking zone to a lower setting, return the meat to the pan and add your sauce.
6. Stir the ingredients gently to make sure they are heated through.
7. Serve immediately.

HEAT SETTINGS

Heat Setting	Suitability
1 - 2	Delicate warming for small amounts of food
	Melting chocolate, butter, and foods that burn quickly
	Gentle simmering
	Slow warming
3 - 4	Reheating
	Rapid simmering
	Cooking rice
5 - 6	Pancakes
7 - 8	Sauteing
	Cooking pasta
9	Stir-frying
	Searing
	Bring soup to the boil
	Boiling water

Using your Freestanding Cooker

USING THE HOTPLATES OF YOUR COOKER

A Word On Induction Cooking

Induction cooking is a safe, advanced, efficient, and economical cooking technology. It works by electromagnetic vibrations generating heat directly in the pan, rather than indirectly through heating the glass surfaces. The glass becomes hot only because the pan eventually warms it up.

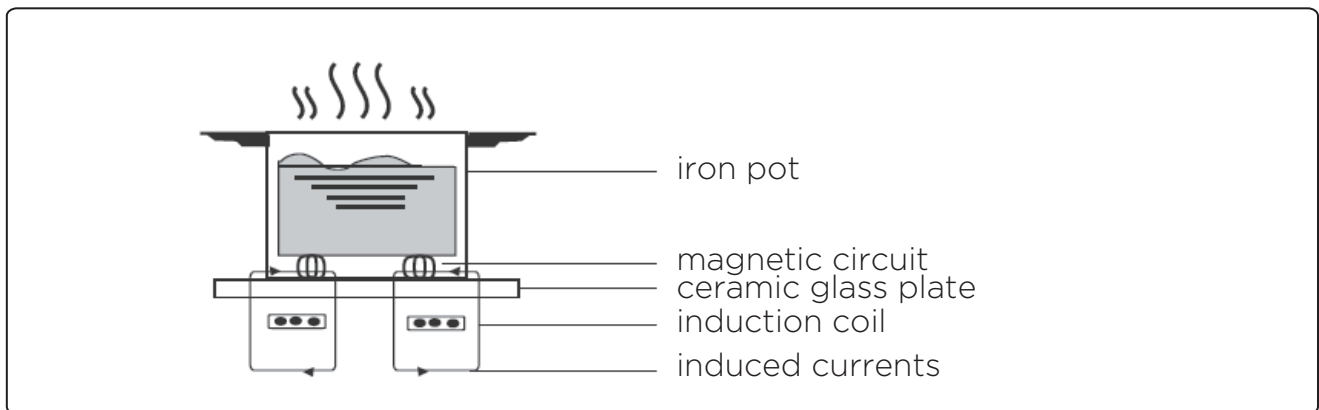

Before using your new cooktop

Read this guide, taking special note of the 'Safety Warnings' section.

Remove any protective film that may still be on your induction hob.

Using the Touch Controls

The controls respond to touch, so you don't need to apply any pressure.

Use the ball of your finger, not its tip.

You will hear a beep each time a touch is registered.

Make sure the controls are always clean, dry, and that there are no objects (e.g. a utensil or a cloth) covering them. Even a thin film of water may make the controls difficult to operate.

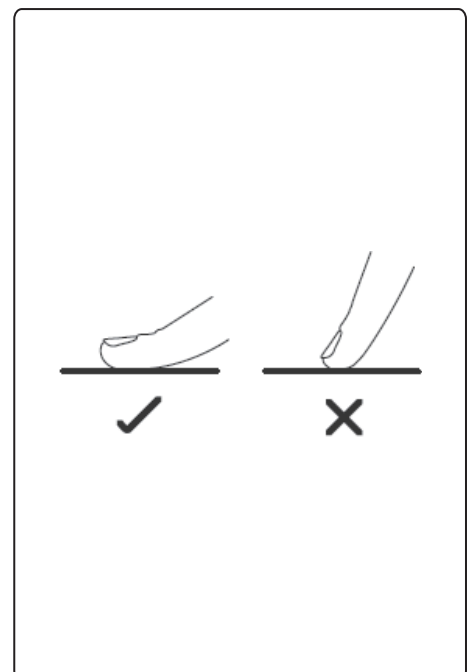

Using your Freestanding Cooker

Choosing the Right Cookware

 Only use cookware with a base suitable for induction cooking. Look for the induction symbol on the packaging or on the bottom of the pan.

You can check whether your cookware is suitable by carrying out a magnet test. Move a magnet towards the base of the pan. If it is attracted, the pan is suitable for induction.

If you do not have a magnet:

1. Put some water in the pan you want to check.
2. Follow the steps under 'To start cooking'.
3. If 'U' does not flash in the display and the water is heating, the pan is suitable.

Cookware made by the following materials is not suitable: pure stainless steel, aluminum or copper without a magnetic base, glass, wood, porcelain, ceramic, and earthenware.

Size of Element (mm)	Minimum Cookware diameter (mm)
160	120
180	140
210	160
280	180

Do not use cookware with jagged edges or a curved base.

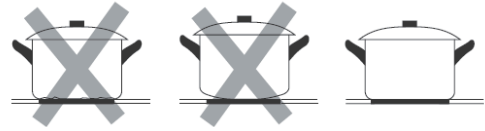

Make sure that the base of your pan is smooth, sits flat against the glass, and is the same size as the cooking zone. Always centre your pan on the cooking zone.

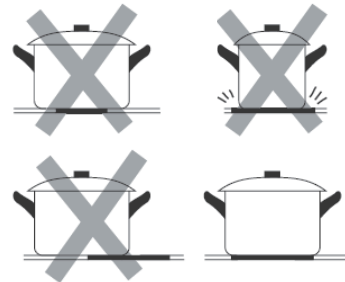

Always lift pans off the ceramic hot - DO NOT slide, or they may scratch the glass.

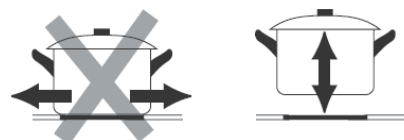

Using your Freestanding Cooker

USING YOUR HOB

To Start Cooking

The hob has 4 cooking zones, each with its own control knob and indicator.

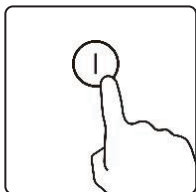

1. Touch the ON/OFF '⓪' key, all the indicators show '–'.

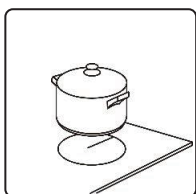

2. Place a suitable pan on the cooking zone that you wish to use. Make sure the bottom of the pan and the surface of the cooking zone are clean and dry.

3. Select the heating zone you wish to use and turn the control knob clockwise. The relevant indicator on the hob for that zone will show the power level selected.

4. Adjust the power level up/down by turning the control knob clockwise / anti-clockwise. The power levels range from **1-9** as well as keep warm (**L1 & L2**) and Boost (**P**) settings. You can modify the power level at any time.

When You Have Finished Cooking

1. Turn the cooking zone off by turning the relevant control knob anti-clockwise back to the off '●' position. The indicator will show '–' or '**H**'.

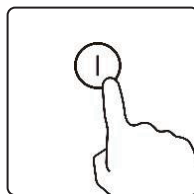

2. Turn the whole hob off by touching the ON/OFF '⓪' key.

Beware of Hot Surfaces

When '**H**' is displayed the cooking zone is too hot to touch. It will disappear when the surface has cooled down to a safe temperature. It can also be used as an energy saving function if you want to heat further pans, use the hotplate that is still hot.

Using your Freestanding Cooker

USING THE BOOST FUNCTION

Activating the Boost Function

1. Adjust the power the relevant zone to level 9 by turning the control knob clockwise.
2. Turn the control knob clockwise briefly to position '**P**'. Allow the control knob to spring back to position '**9**' and the indicator on the hob will show '**p**'.

Cancelling the Boost Function

1. Turn the relevant control knob anti-clockwise to the off '**●**' position, then clockwise to the chosen power level.



The boost function will remain on for 5 minutes, after that the zone will set to level 9 automatically.

KEEP WARM FUNCTION

To use the keep warm function, set the control knob to **L1** or **L2**.

To cancel the keep warm function, turn the control knob back to the off '**●**' position or to another power level setting.

LOCKING THE CONTROLS (CHILD LOCK)

You can lock the controls to prevent unintended use (for example children accidentally turning the cooking zones on).

When the controls are locked, all the controls except the ON/OFF key are disabled.

Using your Freestanding Cooker

To Lock the controls

1. Turn the far left control knob anti-clockwise to the '🔒' symbol for approx 2 seconds. Following a beep, allow the control to spring back to the '●' position and the indicators on the hob for the 2 rear zones will show 'L' and 'O' (Lock).
2. After approx 1 minute, the 'L' and 'O' will disappear but the controls will remain locked. If one of the controls are attempted to be turned on, the 'L' and 'O' will display again.

To Unlock the controls

Repeat the above steps. Following a beep, the 'L' and 'O' will disappear and the controls will unlock.

RESIDUAL HEAT WARNING

Although the hob itself does not heat, when a heating zone has been operating for some time, there will be some residual heat. The letter 'H' appears to warn you to keep away from the particular zone until it has returned to a safe temperature.

AUTO SHUTDOWN

A safety feature of the hob is auto shutdown. This occurs whenever you forget to switch off a cooking zone. The default shutdown times are shown in the table below:

Power level	Max working time
L1	2h
L2	2h
1	8h
2	8h
3	8h
4	4h
5	4h
6	4h
7	2h
8	2h
9	2h

Care and maintenance

Cleaning

WARNING! Isolate the power supply to the appliance and make sure that the cooker is cool.

Before cleaning your cooker or performing maintenance, make sure that the cooking mode selection knob and the cooking temperature selection knob is set to 'OFF'. To extend the life of your cooker, it must be cleaned frequently. The inside of the cooker should preferably be cleaned immediately after use, when it is still warm (but not hot, with warm water and soap. The soap should be rinsed away and the interior dried thoroughly. Avoid using abrasive detergents, scourers, acidic cleaners such as lime scale remover, etc, as these could damage the enamel, and can result in development of rust and corrosion. If stains are particularly tough to remove, use cleaners specifically recommended to clean cookers and follow the instructions provided with the cleaner.

Never use steam cleaner for cleaning inside the cooker.

Do not clean using caustic creams, abrasive cleaning powders, thick wire wool or hard tools. Enamelled parts of the cooker can be damaged if excess cleaning liquids are not immediately removed.

After cleaning the interior parts of the cooker with a soapy cloth, rinse it and then dry thoroughly with a soft cloth.

Clean the glass surfaces with special glass cleaning agents.

Never use flammable agents like acid, thinner or petrol when cleaning your appliance.

Clean the glass surfaces with special glass cleaning agents.

Do not clean your cooker with a steam cleaner.

Do not wash any part of your cooker in a dishwasher.

Enamelled Parts:

In order to keep enamelled parts as new, it is necessary to clean them frequently with mild warm soapy water and then dry with a cloth. Do not wash them while hot and never use abrasive powders or abrasive cleaning materials. Do not leave anything spilled onto enamelled parts for long periods of time.

Ceramic Glass:

The ceramic glass should be regularly cleaned, always wipe clean immediately after each use once the residual heat warnings have switched off - DO NOT clean when hob is still hot. Smudges from pans with an aluminum bottom can be easily cleaned off with a cloth dampened in vinegar. Remove any burnt residues immediately after cooking, rinse with water and wipe dry with a clean cloth. Never use abrasive or corrosive detergents, cleaning powders, oven sprays, spot-removers, steel wool or scourers.

Care and maintenance

Replacing the oven lamps

- Disconnect the oven from the power supply at the fuse-box by means of the switch used to connect the appliance to the electrical mains ;or unplug the appliance.
- Remove the glass cover of the lamp-holder by rotating anti-clockwise.
- Remove the lamp and replace with a lamp resistant to high temperatures (300 °C) with the following characteristics:

Voltage: 220-240V
Wattage: 25W
Type: G9(Halogen lamp)
Energy efficiency class: G

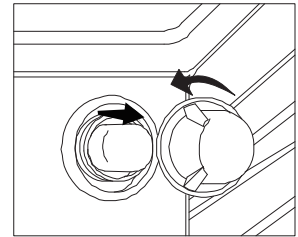

Replace the glass cover. Reconnect the appliance to the mains power supply.

Cleaning the oven door / How to remove the oven doors

For a more thorough clean, you can remove and disassemble the oven door. Proceed as follows:

Oven door removal and assemble procedure:

- Open the door to the full extent (fig.1)
- Open the lever A completely on the left and right hinges (fig.2).
- Hold the door as shown in (fig.3).
- Gently close the door (fig.3) until left and right hinge levers A are hooked to part B of the door (fig.4).
- Withdraw the hinge hooks from their location following arrow C (fig.4).
- Rest the door on a soft surface.
- To replace the door, repeat the above steps in reverse.

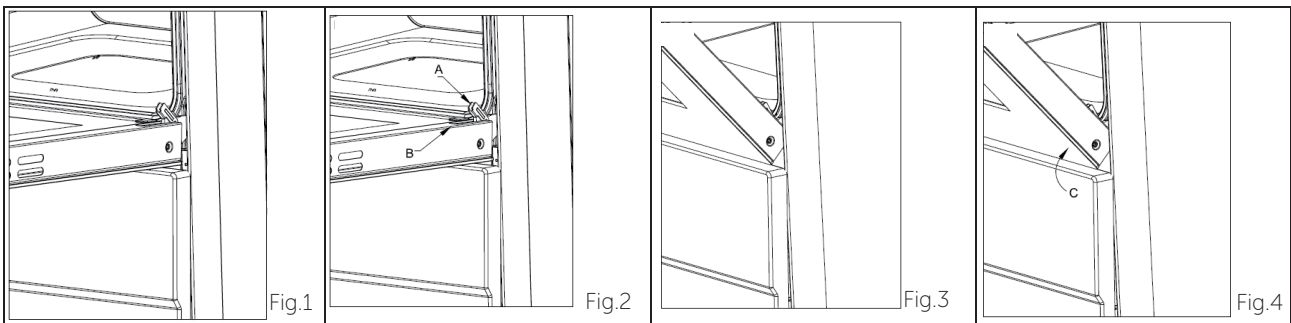

Care and maintenance

Removing the Inner Pane of Glass

- Double oven door: Remove the seal “G” by unscrew the no.2 bolts (Fig.5)
- Gently pull out the inner pane of glass (Fig.6)
- Clean the glass with an appropriate cleaner. Dry thoroughly, and place on a soft surface.
- Now you can also clean the inside of the outer glass.

Cleaning the door glass

Clean the glass door using non-abrasive products or sponges and dry it with a soft cloth.

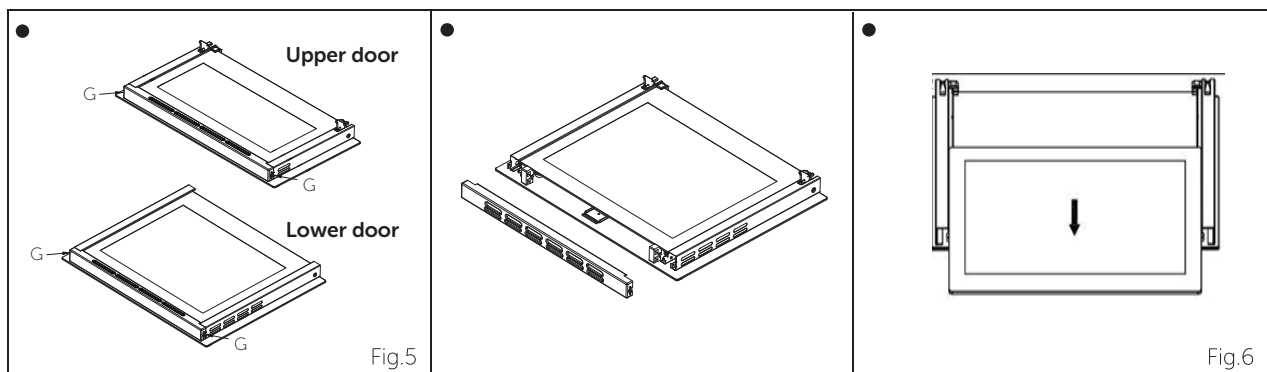

Technical Data

Technical specification

Model	TKED64INDB
Voltage and frequency	220-240V or 380-415V 3N~ 50-60Hz
Upper oven power consumption	1600-1900W
Lower oven power consumption	1710-2030W
Total oven power consumption	3310-3930
Upper oven usable capacity	31L
Lower oven usable capacity	68L
Power consumption for LF zone	3000W
Power consumption for LR zone	1500W
Power consumption for RF zone	1500W
Power consumption for RR zone	2100W
Total ceramic zone power consumption	7200W
Total power consumption	10510-11130W
Energy rating	A
Product dimension	600 x 595 x 900mm

We apologise for any inconvenience caused by minor inconsistencies within these instructions that may occur due to product improvements and development.

All images and drawings are for illustration purposes only.

Technical Data

Energy fiche

Product fiche pursuant to Delegated Regulation(EU) No. 65/2014 and 66/2014		
Brand	TEKNIX	
Large Description	TKED64INDB	
Product Line	FS Cooker with Double Oven	
Net weight(kg)	54 ± 2	
Energy Efficiency Index, EEI Cav 1	73.5	
Energy Efficiency Index, EEI Cav 2	91.0	
Energy efficiency - cavity 1	A+	
Energy efficiency - cavity 2	A	
Energy consumption conventional(kWh) - cavity 1	0.5	
Energy consumption conventional(kWh) - cavity 2	-	
Energy consumption forced air convection(kWh) - cavity 1	-	
Energy consumption forced air convection(kWh) - cavity 2	0.76	
Oven number	2	
Heat source	Electricity	
Cavity capacity(l) - cavity 1	31L	
Cavity capacity(l) - cavity 2	68L	
Power Consumption in standby mode	0.87W (with electric timer)	
Power Consumption in network stand-by mode	-	
Energy Saving Tips Oven	Energy Saving Tips Hob	
- Cook the meals together, if possible.	- Use cookwares having flat base.	
- Keep the pre-heating time short.	- Use cookwares with proper size .	
- Do not elongate cooking time.	- Use cookwares with lid.	
- Do not forget to turn-off the oven at the end of cooking.	- Minimize the amount of liquid or fat.	
- Do not open oven door during cooking period.	- When liquid starts boiling , reduce the setting.	
Type of Hob		Electric
Number of Cooking Zones		4
Heating Technology-1		Induction
Size-1	cm	Ø21
Energy Consumption-1	Wh/kg	180.0
Heating Technology-2		Induction
Size-2	cm	Ø16
Energy Consumption-2	Wh/kg	191.3
Heating Technology-3		Induction
Size-3	cm	Ø18
Energy Consumption-3	Wh/kg	190.0
Heating Technology-4		Induction
Size-4	cm	Ø16
Energy Consumption-4	Wh/kg	204.7
Energy Consumption of Hob	Wh/kg	191.5
This hob complies with EN 60350-2		

Product support

Troubleshooting

If you have a problem with your appliance, check the troubleshooting table below to try and rectify your problem before calling your product support service centre.

Problem	Possible Cause	Solution
Oven will not operate	Control knob is not set in the correct position	Move the control knob in a clockwise direction and select the desired function
Nothing works	Power is turned off at the isolation switch or the consumer unit Poor electrical connection	Ensure isolation switch is on and check the consumer unit has not tripped out Have the connections been checked by a qualified electrician?
The cooking zones are not operating	Poor electrical connection Power is turned off at the isolation switch	Have the connections been checked by an electrician? Ensure the isolation switch is on, check the consumer unit has not tripped out
Oven not heating up	Oven temperature not set correctly Door is not properly closed	Ensure that the correct temperature has been selected and the door is properly closed

Product support

Declaration of conformance to product standards

This appliance conforms to all relevant standards applicable to domestic appliances sold in the UK.

Disposal



This appliance/fitting is marked according to the European directive 2012/19/EU on Waste Electrical and Electronic Equipment (WEEE). By ensuring this product is disposed of correctly, you will help prevent potential negative consequences for the environment and human health, which could otherwise be caused by inappropriate waste handling of this product.

The symbol on the product, or on the documents accompanying the product, the crossed out wheellie bin symbol, indicates that this appliance/fitting may not be treated as household waste. Instead it shall be handed over to the applicable collection point for the recycling of electrical and electronic equipment.

Disposal must be carried out in accordance with local environmental regulations for waste disposal.

For more detailed information about treatment, recovery and recycling of this product, please contact your local authority, your household waste disposal service or the retailer where you purchased the product.



**Your Teknix appliances comes with a 2 year
parts and labour guarantee.**

Please REGISTER your appliance online at

www.teknixwarranty.co.uk



**You also have the option to EXTEND YOUR WARRANTY
to 5 years parts and labour.**

To register your appliance or extend your warranty

Please call 01759 48 78 23

We, Teknix, undertake that if within 24 months of the date of purchase this appliance or any part thereof is proven to be defective by reason of mechanical or electrical failure we will at our discretion repair or replace the same free of any charge for labour, materials or carriage on condition that:

- The appliance has been correctly installed in accordance to manufacturers' instructions.
- The appliance has been used for normal domestic purposes only and in accordance with our operating instructions.
- The appliance has not been repaired, taken apart or tampered with by any person not authorised by us.
- All repair work under this guarantee must be undertaken by the organisation or its authorised agents
- Proof of purchase is available on request
- If we decide your appliance cannot be repaired, or is uneconomical to repair, we'll replace it with the same model. If that model is no longer available, we'll discuss an alternative settlement with you.
- We reserve the right to charge for the expense of a service call if no fault has been found with the appliance after we have inspected it.
- All claims must be arranged via a call to us on 01759 487893. Without pre-authorisation it may result in the cost of claim not being reimbursed.

This guarantee is in addition to your statutory and other legal rights

Exclusions

- Damage resulting from transportation, improper use, or neglect.
- Appliance outside the United Kingdom.
- Consumer replaceable items including, but not limited to, batteries, light bulbs and other consumables.
- Cosmetic damage and/or non-functional parts, which do not affect the normal use of the product including for example cabinet, scratches and rust.
- Any loss suffered as a result of not being able to use the appliance or any loss other than the repair or the replacement cost of the product.
- Accidental or physical damage

